

Electric Lock (24V) Installation Manual

Note: Electric lock improves the safety for your gate, and it is highly recommended if you have animals or live in areas affected by strong winds when the gate is longer than 1.5 meters (7ft).

Electric Lock Part List

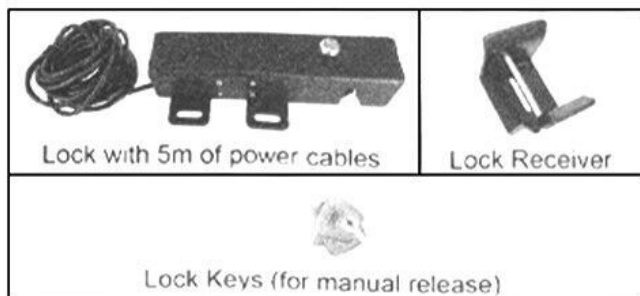

Important Information:

1. Before you install the Electric Lock please be sure the gate is level, moves freely, and does not bind or block against barriers.
2. *On the Pull-to-Open installation, for the Electric Lock to work properly, in order to ensure the lock engaging with the lock receiver firmly, the limit switch B must be moved outward a little bit more than the desired close position.*
3. The Electric Lock must be installed on the outside of the gate if on the **Push-to-Open** gate.
4. Due to the various mounting conditions, mounting hardware is not provided. Read this manual carefully to determine the mounting hardware required for your condition.
5. For dual gate, the lock must be installed on the Master Gate (gate 1) which is near the Control Box, and the lock receiver must be installed on the Slave Gate (gate 2).
(If the gate near the control box has been set up as slave gate, you can change the settings following "User's Manual" → "Control Board Settings" → "Master/Slave Gate Set")

Installation for Single Gate

Step 1: Disengage the clutch of the opener with the Release Key. You can move the gate by hand, so the gate can swing freely during installation of the Electric Lock.

Step 2: With the gate in the closed position, determine the best location for the lock and receiver. The lock and receiver must be level and aligned with the opener. The lock and receiver should have a solid surface or tube fence to provide stability.

Step 3: For **Metallic Tube** gate, if the thickness of the fence post is bigger than or equal to 3mm, you can thread on the fence post, and fasten the lock and receiver only using bolts (without nuts). Otherwise, drill holes through out the fence post, and fasten the lock and receiver with bolts, lock washers and nuts. Of course, you can weld them directly.

For **Chain Link** gate, you will need U-Bolts, saddles, lock washers and nuts for the lock and receiver.

Step 4: Recheck the lock's position and alignment, make sure the electric lock work correctly.

Step 5: Connect the lock's power cables to the control board of swing gate opener (See Figure E).

Note: Be sure that the clutch of the opener is engaged before you prepare to activate your opener (Use the Release Key).

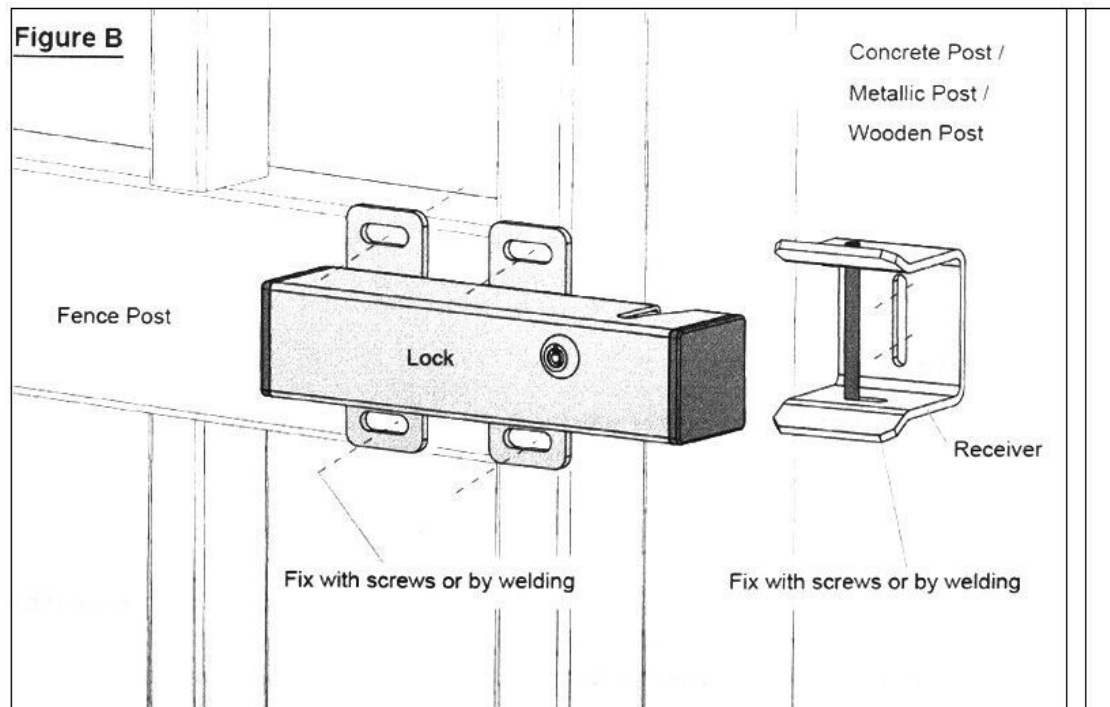
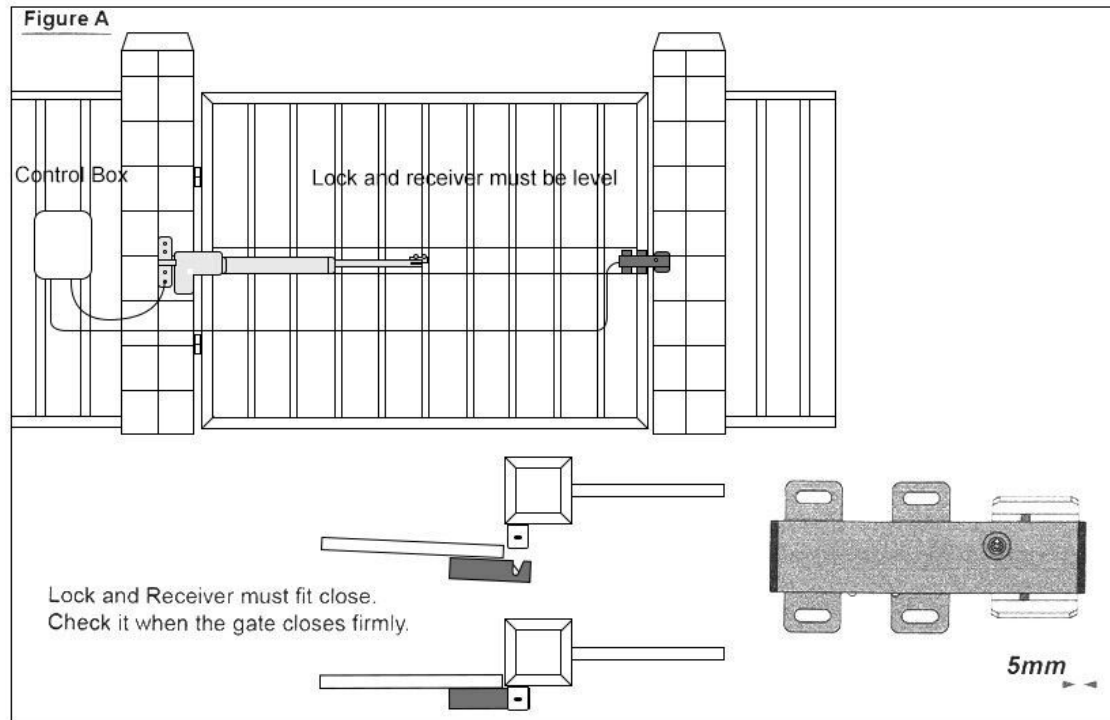

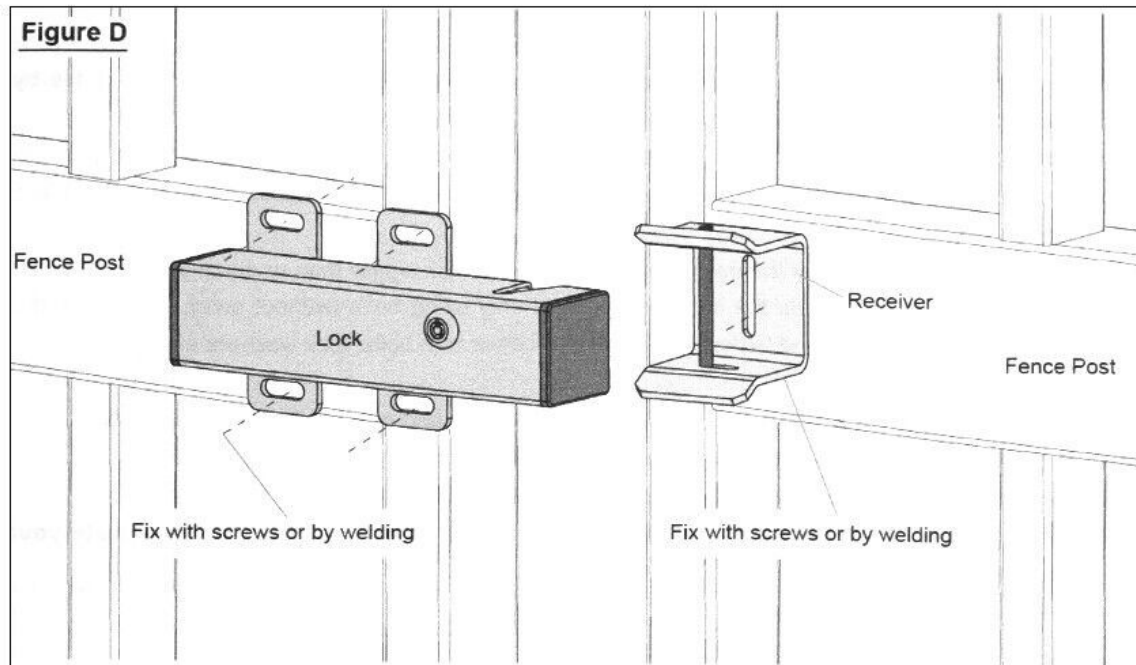

Connecting the Lock to the Control Board of Gate Opener

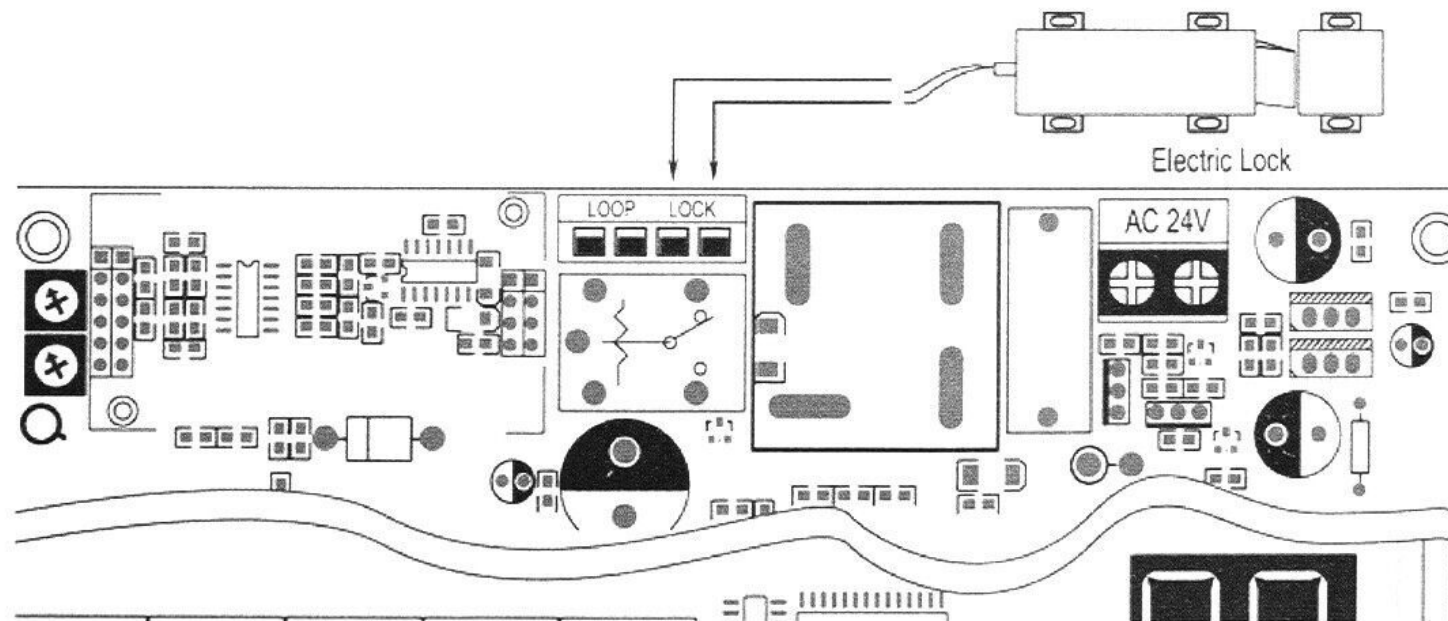

Wiring Diagram of the E-Lock to the MK/LM (KNL 12, 15, 14) Series Swing Gate Opener with electric lock terminal